

Larken StarCNC 32 Controller board

Connection manual

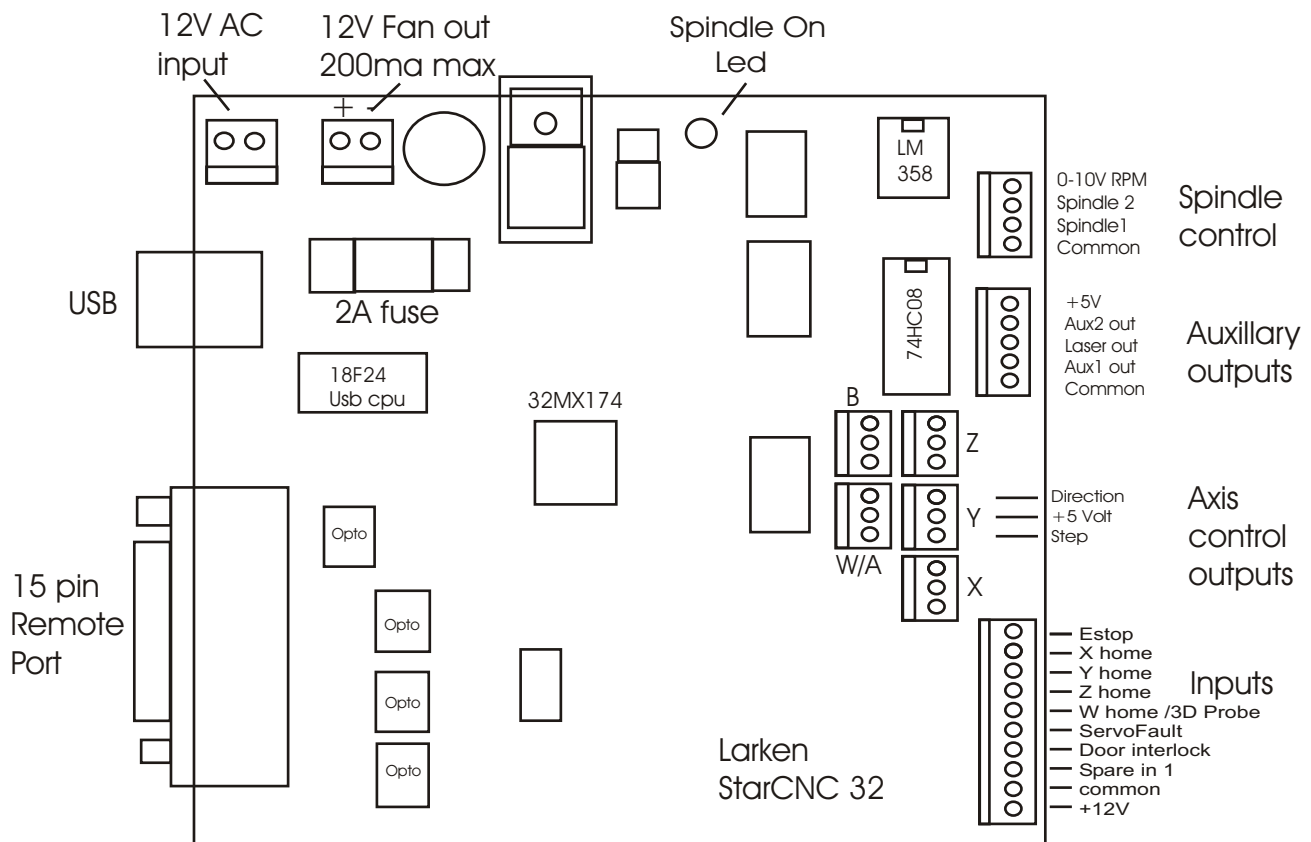

Larken Technology
www.LarkenCNC.com
 Email Larken@Storm.ca

Power and Fan connections

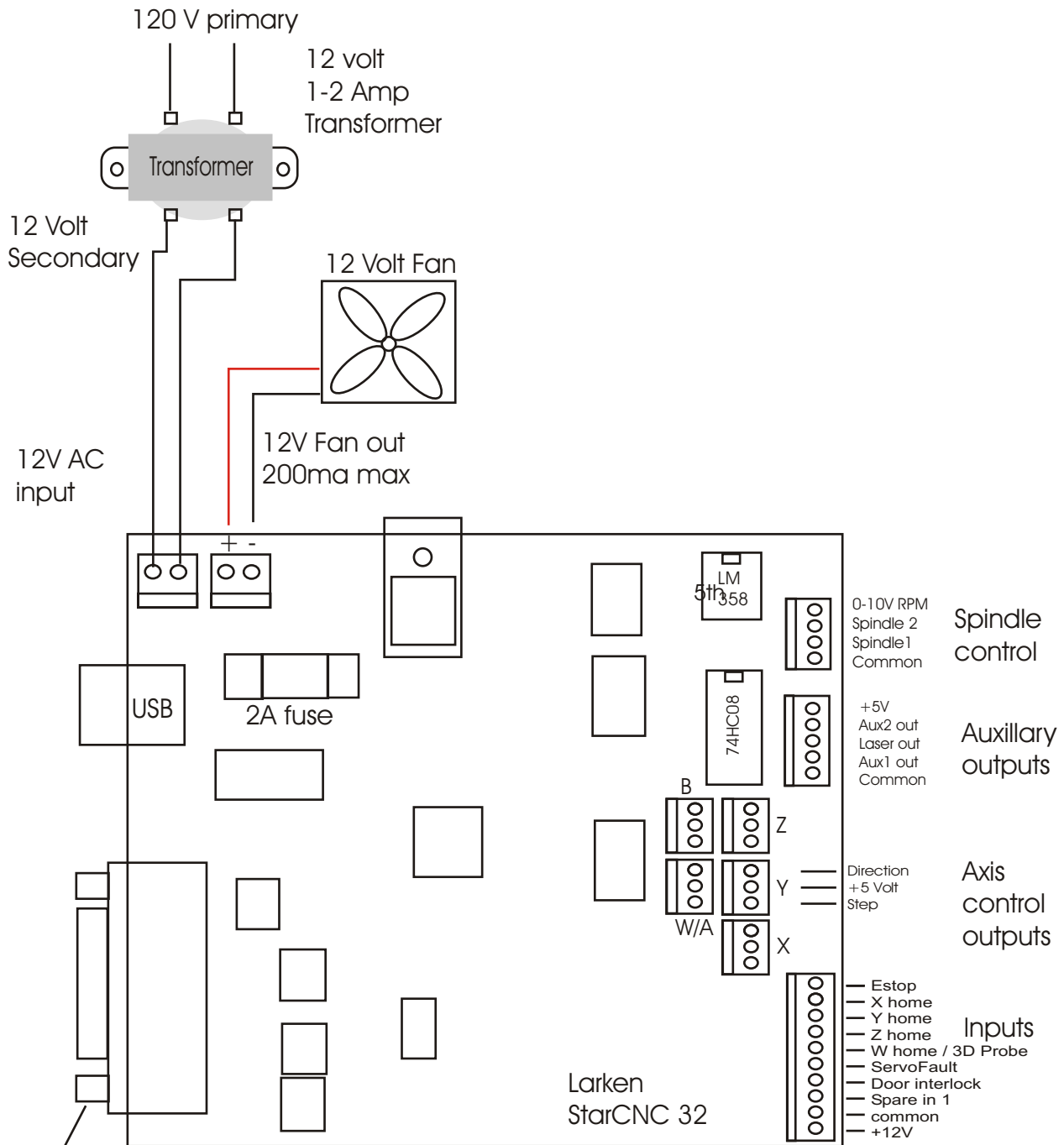

Chassis Grounding required thru mounting plate with Db15 connector

Inputs and Router spindle switching

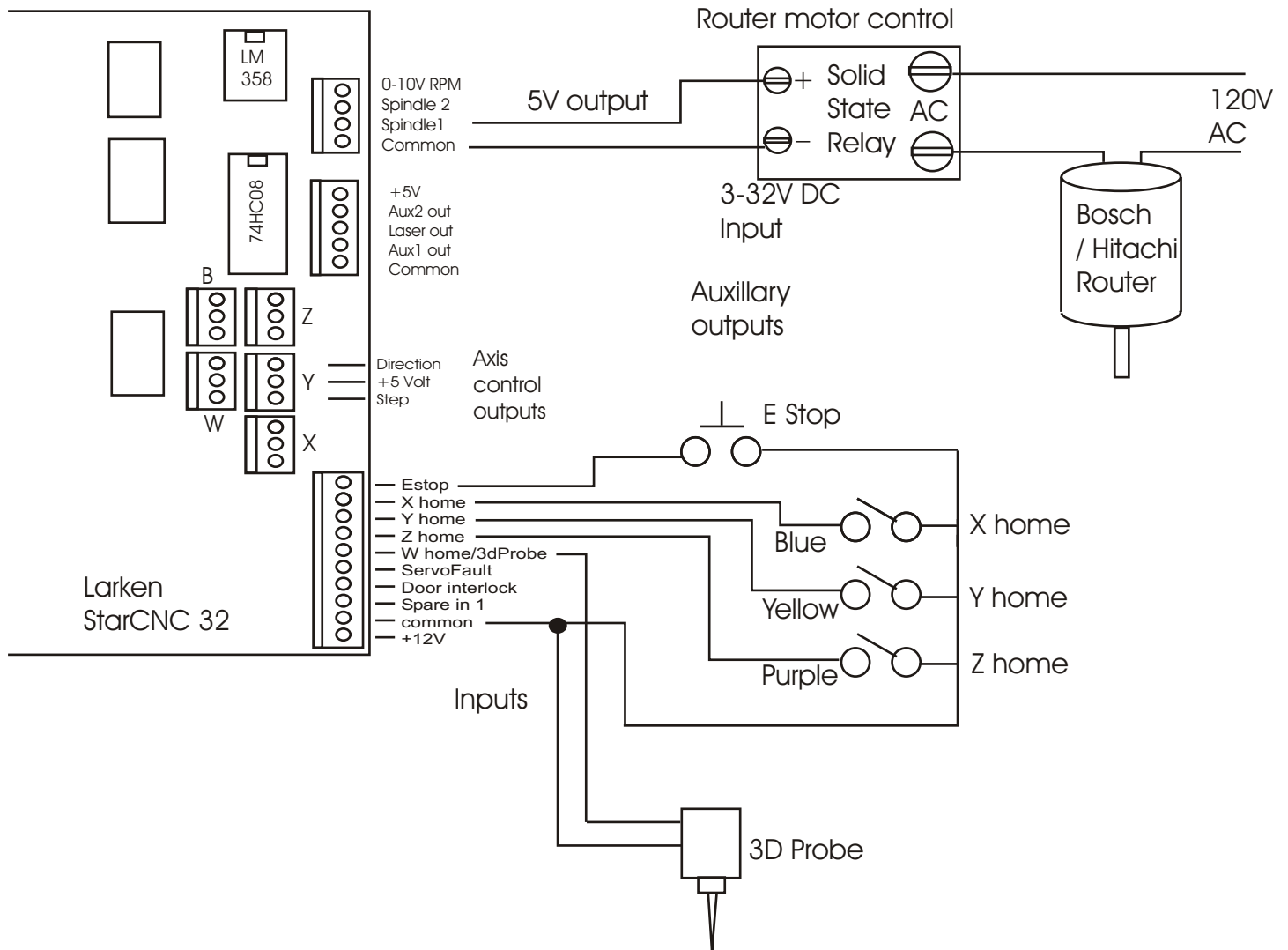

VFD (Variable Frequency Drive) Spindle connection

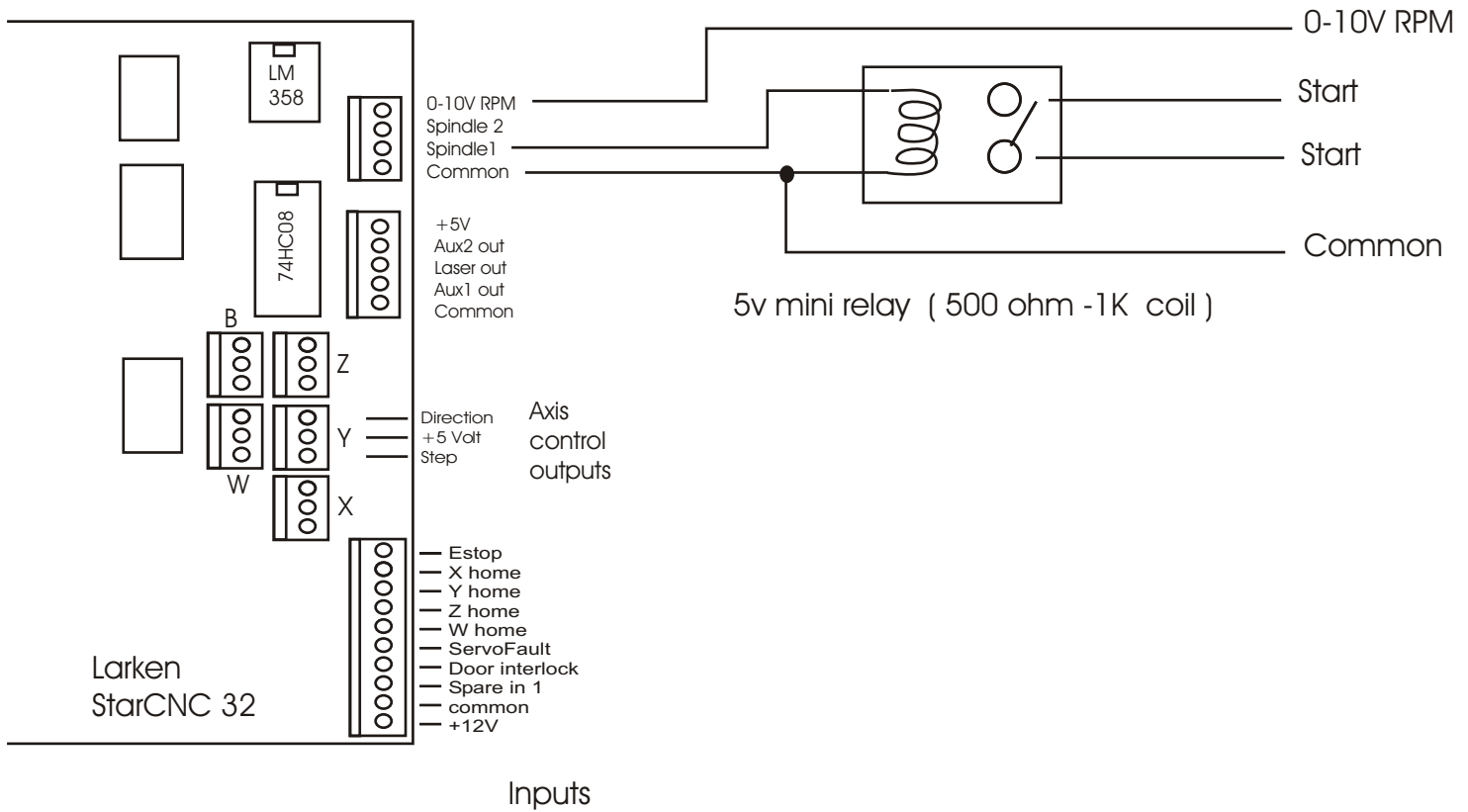

Connecting a Laser to Starcnc for gray scale engraving or cutting

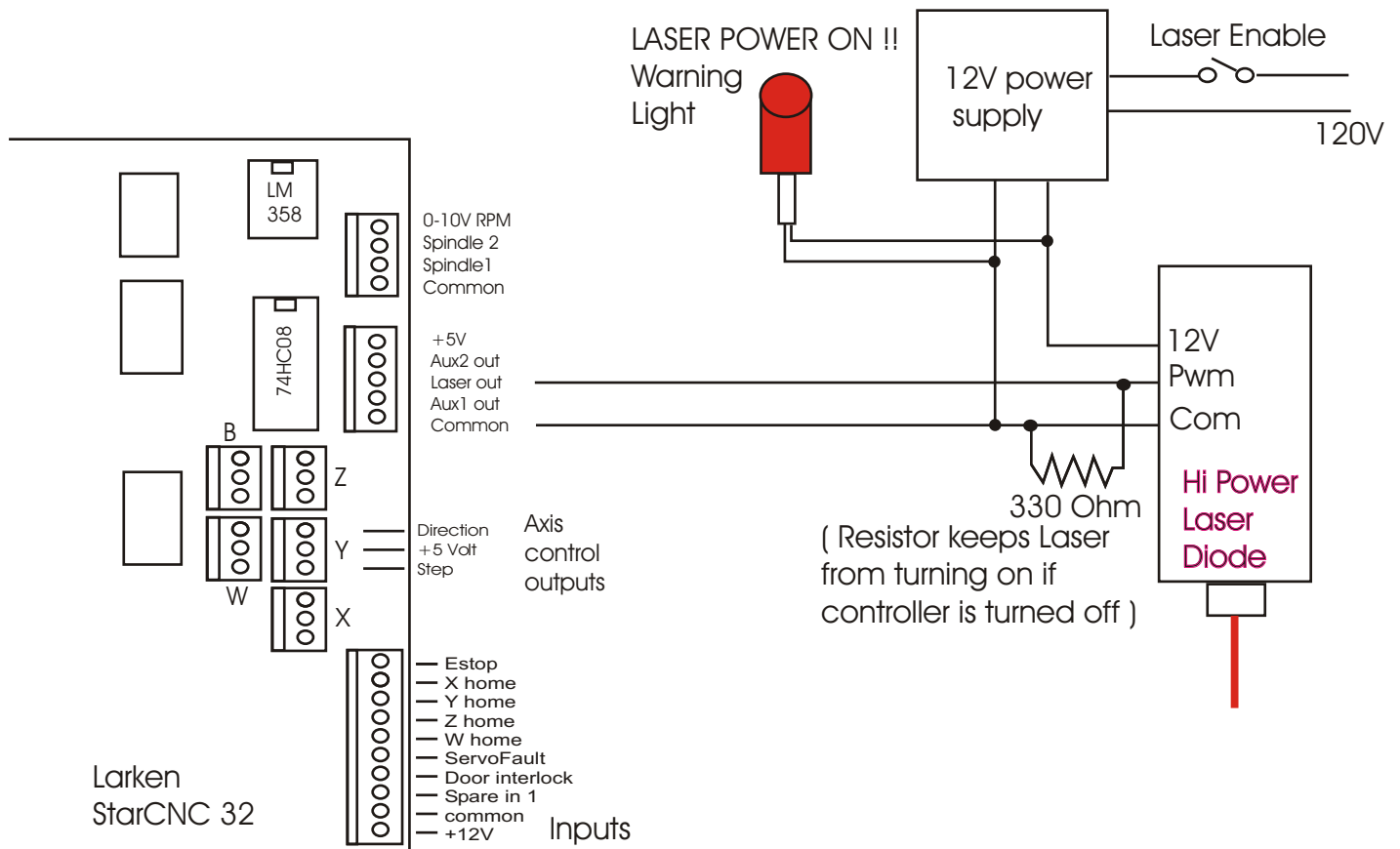

WARNING !
A Laser is VERY DANGEROUS and can cause instant blindness or severe Burns .

Always wear proper Protective Laser Goggles and keep the laser close to the work .
Do not engrave on Reflective materials !

We suggest making a red plexiglass shield around the laser